

CASE

**LEDEFI**  
SOLUÇÕES INDUSTRIAIS

# ASSEMBLY CELL AUTOMATION AND INTEGRATION WITH INDUSTRIAL ROBOT

Automotive sector

# MAIN BENEFITS OBTAINED

---



Production line **optimization and improvement**  
with the integration of new equipment

Better workplace **ergonomics**

## CLIENT

Automotive manufacturer in Sao Paulo, Brazil.

## WHEN

2020

## PROCESS

Assembly cell of heavy truck transmissions, originally configured with two press machines.

# CLIENT AND CONTEXT



# NEEDS AND CHALLENGES

## AUTOMATION FOR NEW PRODUCT AND PRODUCTION INCREASE

Integration of new conveyor system, press machine, industrial robot and vision system.

## CHALLENGES

PLC programming of production automatic sequences using GRAFCET. Integration and safety interlocks with robot, press machine, conveyor, vision system, barcode scanner and safety sensors.





SOLUTIONS DELIVERED

- NEW PLC AND HMI PROGRAMMING WITH PROFINET COMMUNICATION
- PROGRAMMING OF EXISTING PLC'S TO INCLUDE THE NEW PRODUCT
- VISION SYSTEM CONFIGURATION
- TESTS & COMMISSIONING

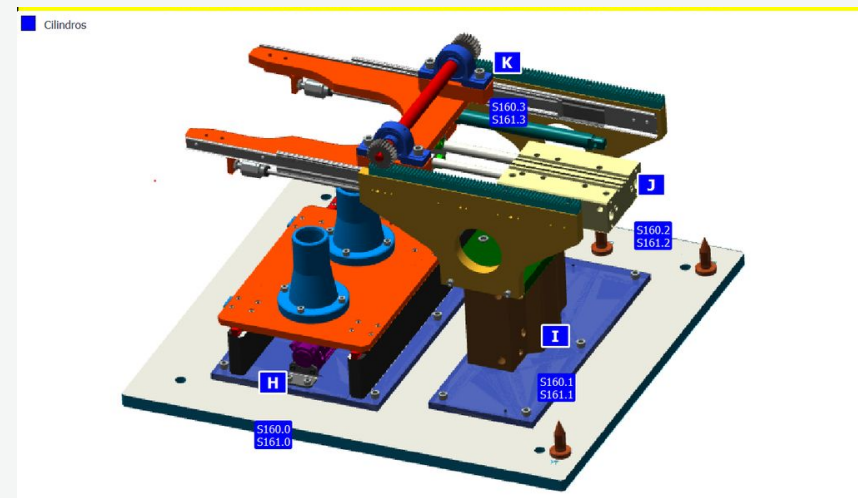
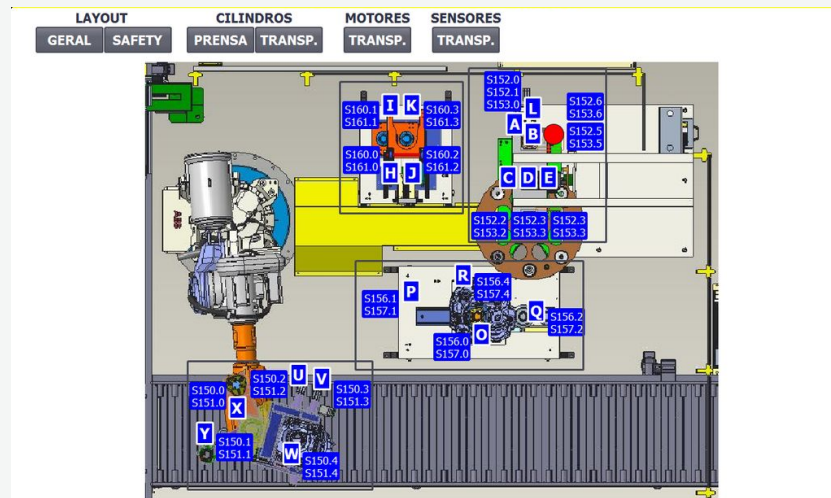

Status	Comandos	Parâmetros
RUN <input checked="" type="checkbox"/>	<b>Trigger</b>	Número do programa <input type="text" value="23"/>
BUSY <input type="checkbox"/>	<b>Carregar Programa</b>	Número de execução <input type="text" value="1"/>
READY <input checked="" type="checkbox"/>	Carregar Número de Execução	
ENABLE <input checked="" type="checkbox"/>	<b>Limpar Resultados</b>	Mensagens
ERROR <input type="checkbox"/>	<b>RESET</b>	Troca de programa OK <input checked="" type="checkbox"/>
		Troca número de execução OK <input type="checkbox"/>
		Trigger OK <input checked="" type="checkbox"/>
		Alarme/falha ativo <input type="checkbox"/>

**Resultados**  
 Pinhão    
 Trava    
 Sede    
 Carcaça    
 Rolamento    
 Copinho

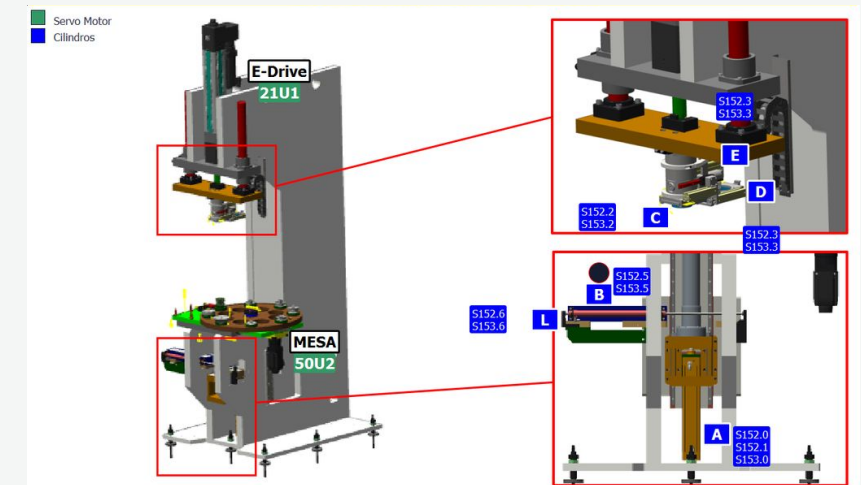

# DELIVERABLES

SIEMENS PLC AND HMI PROGRAMS,  
TESTED AND COMMISSIONED

SOFTWARE DOCUMENTATION

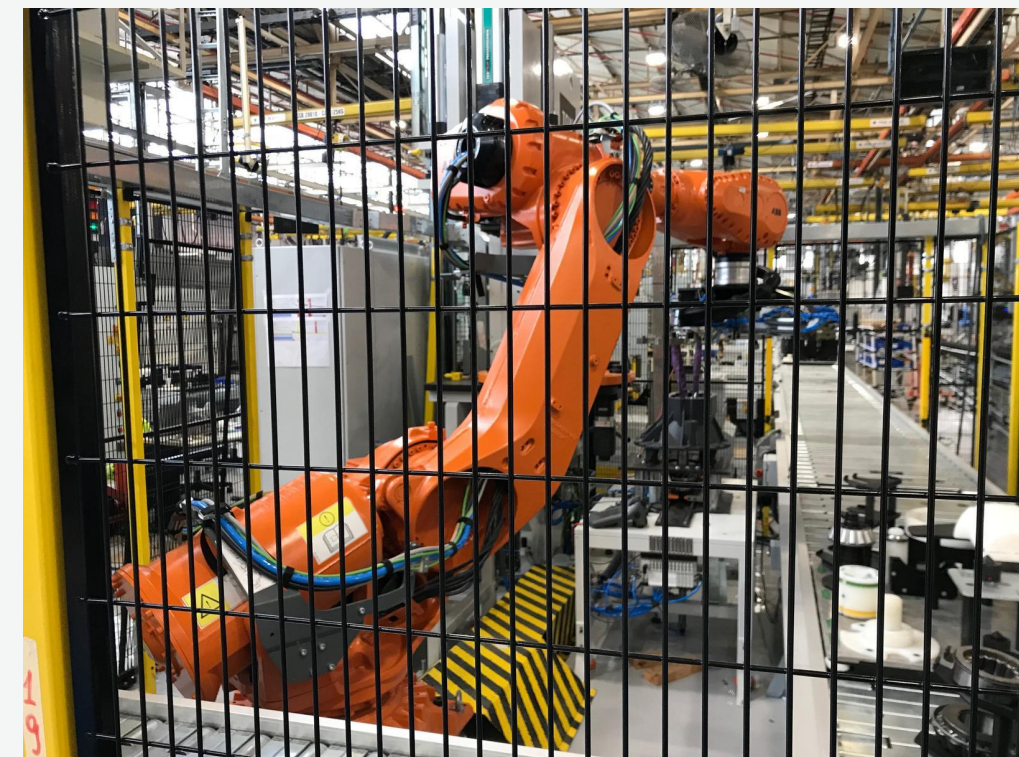

# Technologies & brands

- Siemens PLC and HMI programmed on TIA Portal
- PLC integration with:
  - IO-Link Murrelektronik systems
  - Festo servomotors
  - ABB robot
  - TOX Pressotechnik press machine
  - Keyence vision system
  - Siemens safety hardware

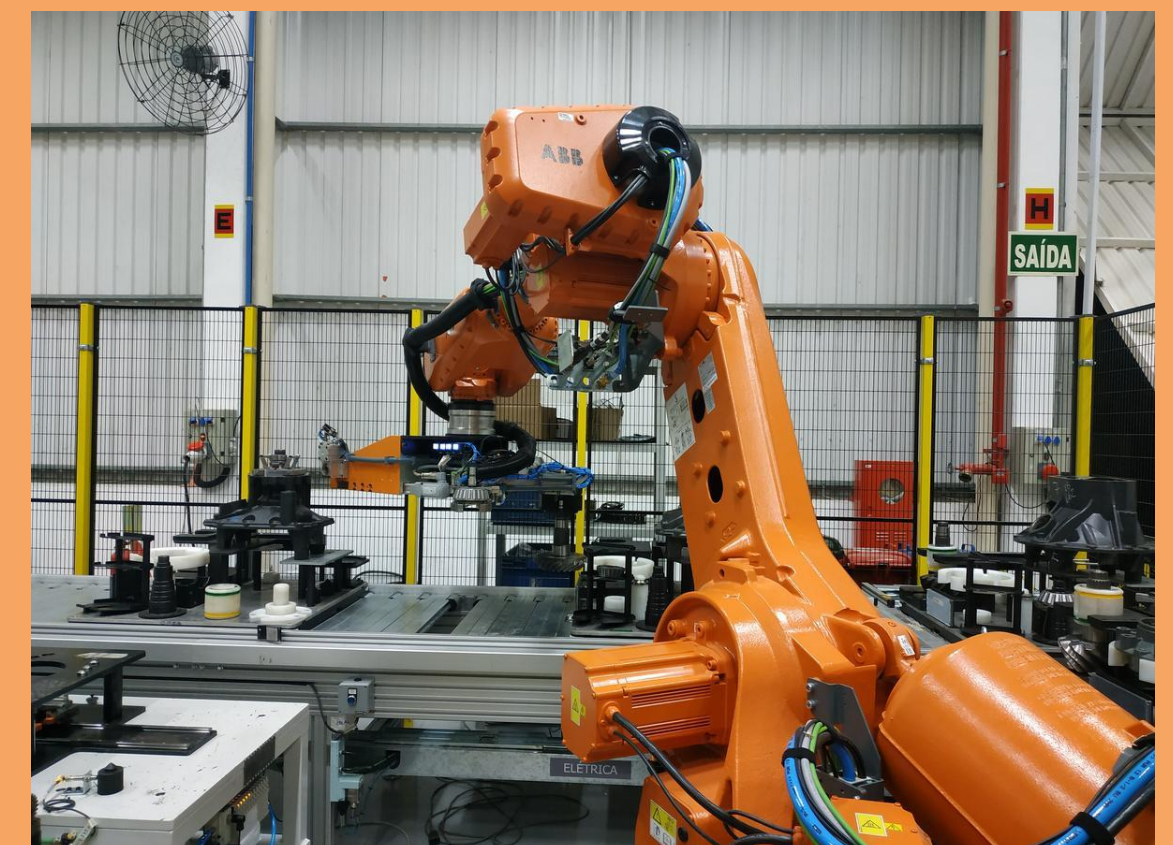



## LOCATION

Itajai, Brazil

## WHATSAPP

+55 47.98858.2917

## E-MAIL

challenges@ledefi.com.br



Please contact us to receive other cases that may be applied to your challenge.

# DRIVEN BY CHALLENGES.

# WHAT'S YOURS?

